

Ersatzteile für
Brenner-Type
WGL30

Spare parts
for burner type
WGL30

Pièces de rechange
pour brûleurs type
WGL30

**Nur für internen
Gebrauch!**

-weishaupt-

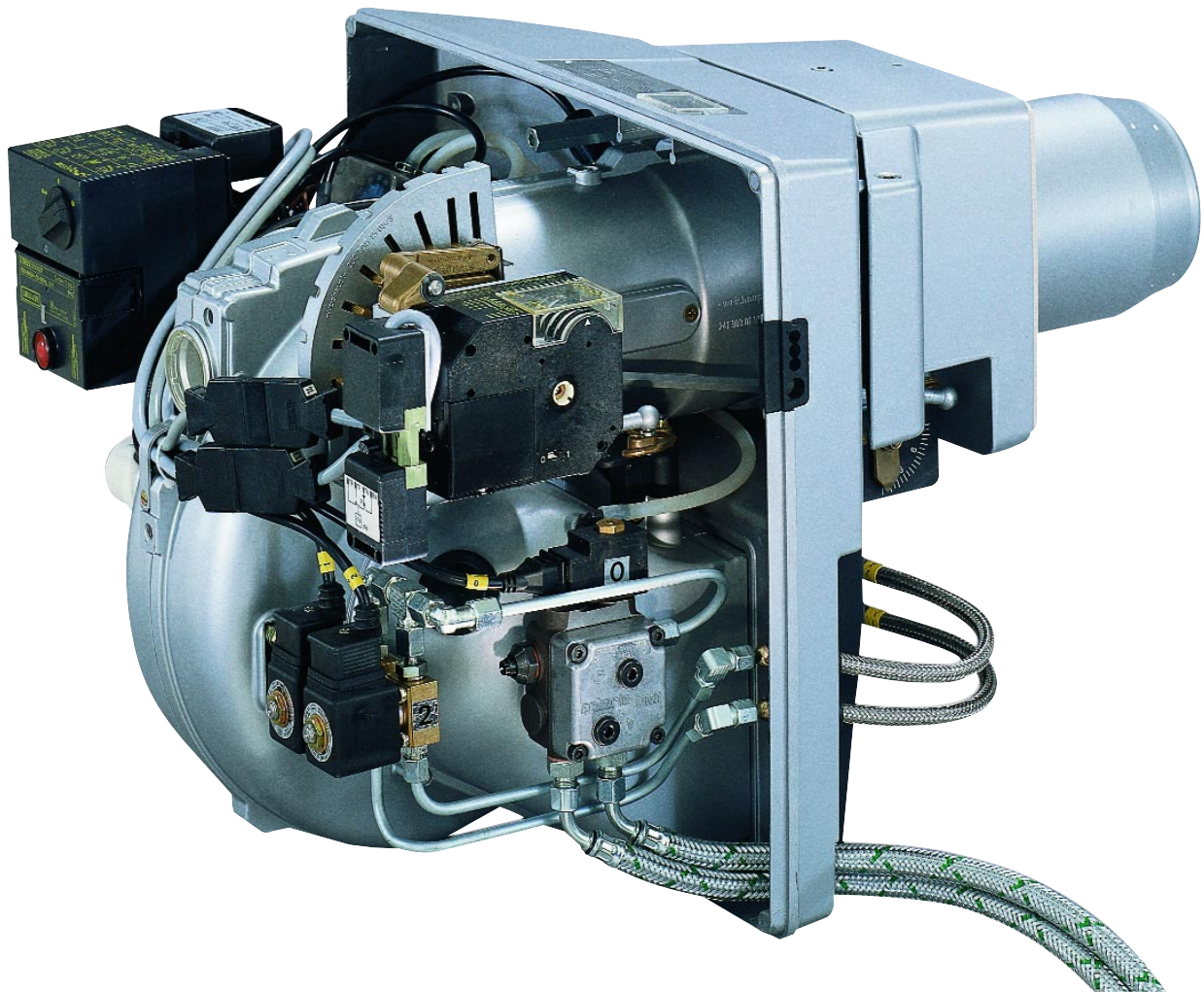

Ersatzteile nach Baugruppen geordnet:

- 1. Brennergehäuse
- 2. Luftregelung
- 3. Stellantrieb
- 4. Gebläserad
- 5. Brennermotor
- 6. Pumpe
- 7. Magnetventil für Öl
- 8. Druckwächter für Luft
- 9. Gasdrossel
- 10. Flammkopf
- 11. Düsenstock WGL30
- 12. Düsen
- 13. Flammenüberwachung
- 14. Zündtrafo
- 15. Armaturen
- 16. Verbindungsteile

← Zurück / Back / Retour



Bild Pict. Photo	Bezeichnung Brenner-Typenreihe Burner serie Type brûleur	Bestell-Nr. Order-No. No de commande		ca. kg appr. kg env. kg	Designation	Désignation
1.	Brennergehäuse				Burner casing	Carcasse Brûleur
1.1	Brennergehäuse	232 300 0101/2	E	3,400	Burner casing	Carcasse Brûleur
1.2	Halteblech	241 300 0126/7	E	0,010	Holding sheet	Support
1.3	Deckel	241 300 0119/7	E	0,027	Cover	Plaquette
1.4	Haltering 42,5 x 48 x 20	232 300 0103/7	E	0,013	Holder	Support
1.5	Schauglas	211 153 0115/7	E	0,005	Sight glass	Verre de visière
1.6	Stopfen	446 014	E	0,004	Closing plug	Bouchon
1.7	Stirnplatte	241 300 0108/7	E	2,700	Front plate	Plaque de front
1.8	Ansauggehäuse	241 300 0111/7	E	0,983	Air intake casing	Carcasse
1.9	Auskleidung	241 300 0115/7	E	0,126	Lining	Isolement
1.10	Brennerflansch WGL30	235 300 0101/7	E	2,360	Flange	Bride
1.11	Klemmschraube M10 x 62	130 301 1402/7	E	0,026	Locking screw	Bouchon hexagonal
1.12	Flanschdichtung 188 x 188 x 128,5	232 300 0102/7	E	0,140	Flange sealing	Joint
1.13	Schalter	700 903	E	0,046	Limit switch	Interrupteur de fin de course
1.14	Gelenkstück	241 300 0112/7	E	0,170	Hinge piece	Pièce de commande
1.15		241 300 0114/7	E	0,175		
1.16	Bolzen M12 x 135	241 300 0121/7	E	0,114	Bolt	Axe
1.17	M12 x 105	241 300 0122/7	E	0,087		
1.18	Sechskantmutter M8 x 108	241 300 0103/2	E	0,118	Lock nut	Contre-écrou
1.19	Abdeckhaube	241 300 0102/2	E	1,780	Cover	Capot
1.20	Schraube M8 x 15	142 013 0115/7	E	0,002	Screw	Vis
1.21	Scheibe 7 x 18 x 0,6	430 016	E	0,001	Disc	Rondelle
1.22	Tülle, für Anschlußkabel für Luftregelgehäuse	241 200 0124/7	E	0,010	Transition nipple	Joint couthouc
1.23		241 200 0119/7	E	0,004		
1.24	Einschraubstutzen 1/8"	453 010	E	0,002	Threaded socket	Raccord droit
1.25	Schutzkappe DN6	232 300 0104/7	E	0,002	Protective sleeve	Capuchon de protection
1.26	Zubehör-Garnitur	232 300 0002/2	E	0,255	Attachment accessoires	Boulons de fixation
1.27	Schauglas	241 200 0121/7	E		Sight glass	Verre de visière
2.	Luftregelung				Air regulation	Régulation d'air
2.1	Luftklappe	241 300 0202/2	E	0,080	Air flap	Clapet d'air
2.2	Welle 7 x 81,5	241 300 0201/7	E	0,021	Shaft	Boudron
2.3	Grundplatte	241 300 0204/2	E	0,049	Ground plate	Plaque
2.4	Kugelzapfen	499 179	E	0,004	Ball end	Rotule
2.5	Verstellhebel	232 300 0204/7	E	0,040	Lever	Levier



Bild Pict. Photo	Bezeichnung Brenner-Typenreihe Burner serie Type brûleur	Bestell-Nr. Order-No. No de commande		ca. kg appr. kg env. kg	Designation	Désignation
3.	Stellantrieb				Servo motor	Servo moteur
3.1	Stellantrieb SQN90-200				Servo motor	Servo moteur
3.2	WGL30	235 300 1502/2	E	0,536		
3.3	Montagebügel	232 300 1501/7	E	0,606	Mounting bracket	Etrier
3.4	Lagerstück	232 300 1502/7	E	0,082	Bearing	Palier
3.5	Stellantrieb 200-240V 50-60 Hz SQN90-200 SQN90-201 für LFL/LGK	651 025 651 030	E E	0,502 0,503	Servo motor	Servo moteur
3.6	Reglerhebel	232 300 1503/2	E	0,303	Regulating lever	Levier de réglage
3.7	Reglerscheibe	232 300 1502/2	E	0,550	Regulating disc	Disque de réglage
3.8	Führungsstück WG30	232 300 1506/7	E	0,015	Guide piece	Butée guide
3.9	Federklammer WG30	232 300 1507/7	E	0,005	Spring clamp	Crampon à ressort
3.10	Stahlband 16 x 0,8 x 145	232 300 1511/7	E	0,014	Steel band	Lame d'acier
3.11	Abdeckblech f. Reglerscheibe	232 300 1508/7	E	0,073	Cover sheet	Capot
3.12	Welle 8 x 8 x 90	232 300 1509/7	E	0,039	Shaft	Bouchon
3.13	Steckerkabel Nr. 2 3-pol.	232 300 1509/2	E	0,107	Cable	Câble
3.14	Regelgestänge Luft	232 300 1514/2	E	0,080	Regulating rod (air)	Tige de réglage (air)
3.15	Gas	232 300 1506/2	E	0,094	(gas)	(gaz)
3.16	Buchseinteil ST 18/4	716 086	E	0,032	Sleeve part	Douille pour fiche
3.17	Steckerteil ST 18/4	716 087	E	0,031	Plug part	Douille pour prise
3.18	Potentiometer ASZ 8,703 220 Ohm ASZ 12,703 1000 Ohm	651 432 651 433	E E	0,015 0,015	Potentiometer	Potentiometre
3.19	Adapter AGA 09	651 031	E	0,005	Adaptor	Adapteur
4.	Gebläserad				Blower	Ventilation
4.1	Gebläserad, 50 Hz 170 x 70, verzinkt	241 300 0801/2	E	0,485	Blower	Turbine
4.2	Unterlegscheibe für Gebläseradbefestigung	141 111 0802/7	E	0,002	Washer for blower wheel attachment	Rondelle plate pour fixation turbine
4.3	Schraube M4 x 12	402 112	Z	0,002	Screw	Vis
4.4	Federring B4	435 100	Z	0,001	Spring ring	Rondelle ressort
4.5	Scheibenfeder 3 x 3,7	490 157	E	0,001	Woodruff key	Clavette disque
4.6	Abziehvorrichtung	141 213 0003/2	E	0,125	Blower remover	Arrache turbine

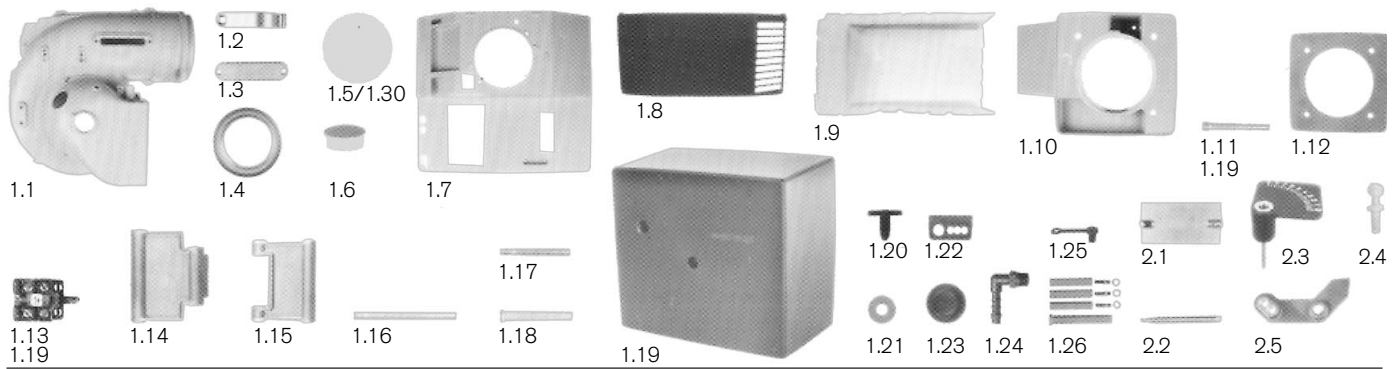

5.1

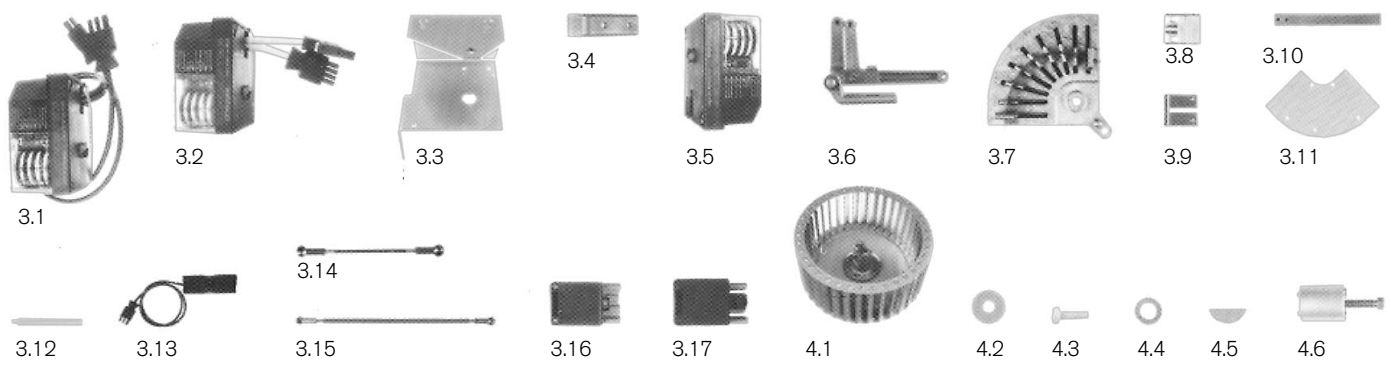

5.3



6.1



6.5



6.6



6.7



6.8



6.21

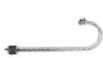

6.31



6.32



6.33



6.34



6.35



6.36

Bild Pict. Photo	Bezeichnung Brenner-Typenreihe Burner serie Type brûleur	Bestell-Nr. Order-No. No de commande		ca. kg appr. kg env. kg	Designation	Désignation
5.	Brennermotor Bei Bestellung Spannung und Frequenz angeben. Brennermotor, 50 Hz mit Befestigungsschrauben Typ V Upm ECK 05-2 230 2800				Burner motor When ordering indicate voltage and frequency Burner motor	Moteur brûleur A la commande indiquer la tension et la fréquence Moteur de brûleur
5.1		241 300 0709/0	E	7,320		
5.2	Kondensator 12µF, zu Motor ECK 05-2	713 121	E	0,082	Capacitor	Condensateur
5.3	Schutzkappe für Kondensator DN40 für ECK 05-2	241 300 0708/7	E	0,006	Protective sleeve for capacitor	Capuchon de protection pour condensateur
6.	Pumpe				Pump	Pompe
6.1	Pumpe AL65	601 192	E	1,065	Pump UNI 1.2	Pompe UNI 1.2
6.2	Anschlußteile (o.B.)	230 300 0601/2	E	0,066	Connection parts	Pièces de raccordement
6.3	Filtersatz Nr. 1 AL65	601 101	E	0,005	Filter	Filtre
6.4	Magnetspule AL (o.B.) 185-254 V, 50-60 Hz	604 429	E	0,520	Solenoid valve coil	Bobine de vanne
6.5	Manometeranschluß	140 013 8505/2	E	0,060	Manometer connection	Raccordement manomètre
6.6	Pumpenkupplung	241 300 0901/2	E	0,057	Pump coupling	Accouplement de pompe
6.7	Kupplungsmittelstück	241 200 0901/7	E	0,024	Intermediate piece	Pièce intermédiaire
6.8	Steckerkabel Nr. 1 3-polig	235 300 1202/2	E	0,046	Connection cable	Câble de raccordement
6.20	Ölschläuche für Ölpumpen als Ansaug- und Rücklaufschlauch Für Heizöl bis max. 70°C				Oil hoses for oil pump as suction intake and return hose For fuel oil EL up to max. 70°C Length mm Connection	Flexibles fuel pour pompe aspiration et refoulement Pour FOD max. 70°C Longueur mm Raccord DN=ID
6.21	DN8 Länge mm 900 Anschluß G 3/8"	491 127	E	0,210		
6.22	DN8 Länge mm 1200 Anschluß G 3/8"	491 128	E	0,282		
6.30	Ölleitungen				Oil lines	Canalisation fuel
6.31	Pumpe - Magnetventil	235 300 0601/8	E	0,035	Pumpe-Solenoid valve	Pompe-Vanne magnetique
6.32	Magnetventil - Druckschlauch	235 300 0602/8	E	0,033	Valve-pressure hose	Vanne-Flexible h.p.
6.33		235 300 0603/8	E	0,044		
6.34	Druckschlauch DN6(5), 320 lg	491 229	E	0,050	Pressure hose	Flexible h.p.
6.35	Schneidring D6-LL	452 801	E	0,001	Cutting ring	Olive
6.36	Überwurfmutter M6-LL	452 800	E	0,006	Union nut	Contre écrou



7.1-7.4 7.5-7.8 7.9

Bild Pict. Photo	Bezeichnung Brenner-Typenreihe Burner serie Type brûleur	Bestell-Nr. Order-No. No de commande		ca. kg appr. kg env. kg	Designation	Désignation
7.	Magnetventil für Öl				Solenoid valve for oil	Vannes magné- tique fuel
	Magnetventil Typ 121 C2323, G1/8" für leichtes Heizöl, stromlos geschlossen Spule 9 Watt				Solenoid valve for light fuel currentless closed	Vanne magnétique type pour FOD, fermée hors tension
7.1	110V/50-60 Hz	604 450	E	0,250		
7.2	230V/50-60 Hz	604 451	E	0,250		
	Magnetventil Typ 131 M 14, G1/8" für leichtes Heizöl, stromlos geschlossen Spule 2 Watt				Solenoid valve for light fuel currentless closed	Vanne magnétique type pour FOD, fermée hors tension
7.3	110V/50-60 Hz	604 390	E	0,149		
7.4	230V/50-60 Hz	604 378	E	0,149		
	Magnetspule Nr. 483764, für Ventil 121 C 2323				Solenoid valve coil for valve	Bobine de vanne magnétique pour vanne
7.5	110V, 50-60 Hz	604 452	E	0,135		
7.6	230V, 50-60 Hz	604 453	E	0,135		
	Magnetspule Nr. 488980, für Ventil 131 M 14				Solenoid valve coil for valve	Bobine de vanne magnétique pour vanne
7.7	110V, 50-60 Hz	604 380	E	0,155		
7.8	230V, 50-60 Hz	604 379	E	0,055		
7.9	Montagebügel	235 300 1301/7	E	0,049	Attachment bracket	Etrier
7.10	Steckerkabel Nr. 2, 3-polig Düse 1 Nr. 6, 2-polig Düse 2	235 300 1203/2 235 300 1205/2	E E	0,078 0,066	Connection cable	Câble de raccordement



Bild Pict. Photo	Bezeichnung Brenner-Typenreihe Burner serie Type brûleur	Bestell-Nr. Order-No. No de commande		ca. kg appr. kg env. kg	Designation	Désignation
8.	Druckwächter für Luft				Pressure monitor	Pressostat
8.1	Druckwächter LGW50 A2 2,5-50 mbar	691 371	E	0,162	Pressure monitor	Pressostat
8.2	Silikonschlauch 3,5 x 2 (o. Bild)	750 418	E	0,029	Silicon-hose	Flexibles silikon
8.3	Schlauchklemme	790 218	E	0,001	Clamp	Crampon
8.4	Einschraubstutzen R 1/8"	453 003	Z	0,001	Threaded socket	Raccord droit
8.5	Steckerkabel Nr. 11, 3 polig	232 300 2401/2	E	0,016	Cable	Câble
9.	Gasdrossel				Gas throttle	Clapet gaz
9.1	Gasdrossel AN 35 mit Drehfeder	232 300 2502/0	E	0,329	Gas throttle	Clapet gaz
9.2	Grundplatte	232 300 2505/7	E	0,014	Base plate	Plaque de base
9.3	Verstellhebel	232 300 0204/7	E	0,040	Adjusting lever	Levier
9.4	Dichtung 35 x 55 x 2	232 300 2504/7	E	0,004	Sealing	Joint
9.5	Drehfeder 0,5 x 4,4	232 300 2506/7	E	0,004	Spring	Lame d'acièr



Bild Pict. Photo	Bezeichnung Brenner-Typenreihe Burner serie Type brûleur	Bestell-Nr. Order-No. No de commande		ca. kg appr. kg env. kg	Designation	Désignation
10.	Flammkopf				Combustion head	Tête de combustion
10.1	Flammrohr W30/1	241 300 1402/2	E	0,860	Flame tube	Tube de combustion
10.2	Mischgehäuse, komplett	235 300 1405/2	E	0,324	Mixing casing	Chambre de mélange
10.3	Stauscheibe 105 x 33	232 300 1405/2	E	0,324	Air diffuser assembly	Défecteur
10.4	Bügel	232 200 1443/7	E	0,018	Bracket	Etrier
10.5	Mischgehäuse	232 300 1401/7	E	0,387	Mixing chamber	Chambre de mélange
10.6	Mischrohr innen 60 x 155	151 101 1420/7	E	0,390	Mixing tube, inside	Tube de mélange
10.7	Mischrohr außen 80 x 95	151 101 1431/7	E	0,304	Mixing tube, outside	
10.8	Verteilerring	232 300 1403/7	E	0,119	Distributor ring	Bague de distribution
10.9	Düsenkopf	235 300 1404/2	E		Nozzle head	Ligne de gicleur
10.10	Elektrodenhalter	232 300 1402/7	E	0,041	Electrode holder	Support électrodes
10.11	Scheibe	151 327 1436/7	E	0,010	Disc	Rondelle
10.12	Haltering	151 101 1425/7	E	0,026	Supporting ring	Joint torique
10.13	Zündelektrode links	155 327 1420/7	E	0,042	Ignition electrode	Électrode d'allumage
10.14	Zündelektrode rechts	151 327 1433/7	E	0,042	Ignition electrode	
	Flammkopfverlängerung (ohne Bild)				Combustion head extension (without picture)	Rallonge de tête de combustion (sans photo)
10.30	Verlängerung mm					
	100	230 300 1404/0	E			
	200	230 300 1405/0	E			
	300	230 300 1406/0	E			
11.	Düsenstock				Nozzle assembly	Ligne de gicleur
11.1	Düsenkopf, Düse 1	235 300 1402/2	E	0,070	Nozzle head, nozzle 1	Ligne de gicleur
11.2	Düsenkopf, Düse 2	235 300 1403/2	E	0,076	Nozzle head, nozzle 2	
11.3	Schneidring 6LL	452 801	Z	0,002	Cutting ring	Olive
11.4	Überwurfmutter 6LL	452 800	Z	0,006	Union nut	Centre écrou

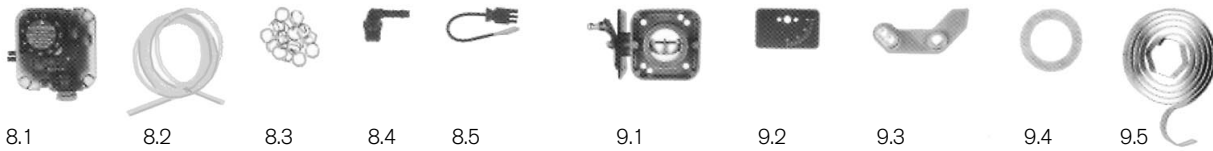

12.1

Bild Pict. Photo	Bezeichnung Brenner-Typenreihe Burner serie Type brûleur	Bestell-Nr. Order-No. No de commande		ca. kg appr. kg env. kg	Designation	Désignation
12.	Düsen				Nozzles	Gicleurs
	Düsen Fabrikat Monarch				Monarch manufacture	Fabrication Monarch
12.1	Größe in US Gph bei 8 bar Typ R - 45° Vollstrahl				Size in US gph at 8 bar Solid spray	grandeur en US Gph à 8 bar Cône-plein
	0,50	602 293	E	0,027		
	0,60	602 294	E	0,027		
	0,65	602 295	E	0,027		
	0,75	602 296	E	0,027		
	0,85	602 297	E	0,027		
	1,00	602 298	E	0,027		
	1,10	602 316	E	0,027		
	1,20	602 305	E	0,027		
	1,25	602 317	E	0,027		
	1,35	602 306	E	0,027		
	1,50	602 307	E	0,027		
	1,65	602 308	E	0,027		
	1,75	602 309	E	0,027		
	2,00	602 310	E	0,027		
	2,25	602 311	E	0,027		
	2,50	602 312	E	0,027		
	3,00	602 313	E	0,027		
	3,50	602 314	E	0,027		
12.2	Düsen Fabrikat Monarch				Monarch manufacture	Fabrication Monarch
	Größe in US Gph bei 8 bar Typ R - 60° Vollstrahl				Size in US gph at 8 bar Solid spray	grandeur en US Gph à 8 bar Cône-plein
	0,50	602 343	E	0,027		
	0,60	602 344	E	0,027		
	0,65	602 345	E	0,027		
	0,75	602 346	E	0,027		
	0,85	602 347	E	0,027		
	1,00	602 348	E	0,027		
	1,10	602 355	E	0,027		
	1,20	602 356	E	0,027		
	1,25	602 357	E	0,027		
	1,35	602 358	E	0,027		
	1,50	602 359	E	0,027		
	1,65	602 360	E	0,027		
	1,75	602 361	E	0,027		
	2,00	602 362	E	0,027		
	2,25	602 363	E	0,027		
	2,50	602 364	E	0,027		
	3,00	602 365	E	0,027		
	3,50	602 366	E	0,027		
12.3	Düsen Fabrikat Steinen				Steinen manufacture	Fabrication Steinen
	Größe in US Gph bei 8 bar Typ S - 45° Vollstrahl				Size in US Gph at 8 bar Solid spray	grandeur en US Gph à 8 bar Cône plein
	0,50	612 001	E	0,025		
	0,55	612 007	E	0,025		
	0,60	612 002	E	0,025		
	0,65	612 051	E	0,025		
	0,75	612 004	E	0,025		
	0,85	612 006	E	0,025		
	1,00	612 008	E	0,025		
	1,10	612 009	E	0,025		
	1,25	612 011	E	0,025		
	1,35	612 012	E	0,025		
	1,50	612 013	E	0,025		

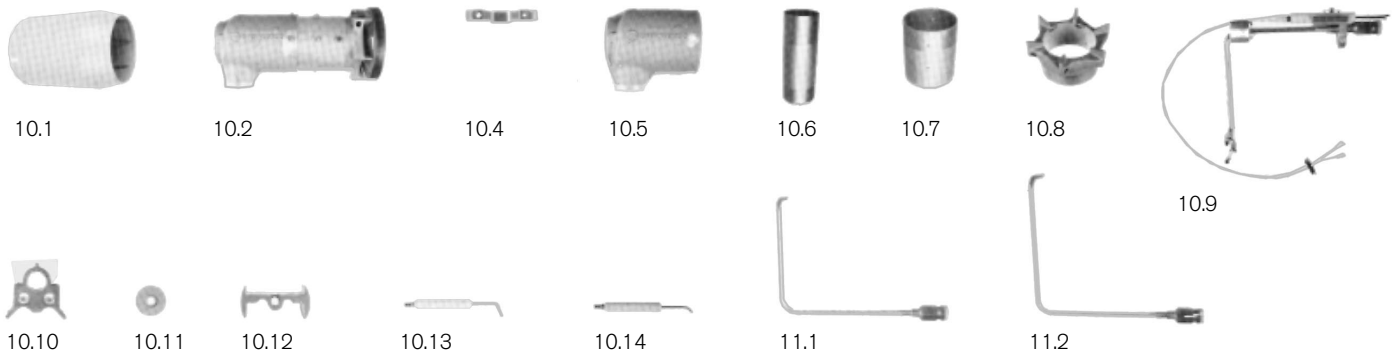
Bild Pict. Photo	Bezeichnung Brenner-Typenreihe Burner serie Type brûleur	Bestell-Nr. Order-No. No de commande		ca. kg appr. kg env. kg	Designation	Désignation
12.4	Düsen Fabrikat Steinen				Steinen manufacture	Fabrication Steinen
	Größe in US Gph bei 8 bar				Size in US Gph at 8 bar	grandeur en US Gph
	Typ S - 60° Vollstrahl				Solid spray	à 8 bar
	0,50	612 200	E	0,025		
	0,55	612 202	E	0,025		
	0,60	612 201	E	0,025		
	0,65	612 250	E	0,025		
	0,75	612 203	E	0,025		
	0,85	612 206	E	0,025		
	1,00	612 207	E	0,025		
	1,10	612 208	E	0,025		
	1,25	612 210	E	0,025		
	1,35	612 211	E	0,025		
	1,50	612 212	E	0,025		
	1,65	612 213	E	0,025		
	1,75	612 214	E	0,025		
	2,00	612 216	E	0,025		
	2,25	612 217	E	0,025		
	2,50	612 251	E	0,025		
	2,75	612 218	E	0,025		
3,00	612 219	E	0,025			
3,50	612 220	E	0,025			



Bild Pict. Photo	Bezeichnung Brenner-Typenreihe Burner serie Type brûleur	Bestell-Nr. Order-No. No de commande		ca. kg appr. kg env. kg	Designation	Désignation
13.	Flammenüberwachung				Burner control	Coffret de sécurité
13.1	Feuerungsautomat LGB 22.330 220V-240V, 50-60 Hz	600 215	E	0,226	Burner control	Coffret de sécurité
13.2	Feuerungsautomat, 230V, 50-60 Hz LFL 1.122 LFL 1.322 LFL 1.335	600 161 600 163 600 172	E E E	1,000 1,000 1,000	Burner control	Coffret de sécurité
13.3	Feuerungsautomat LGK 16.322 230V, 50-60 Hz	600 195	E	0,990	Burner control	Coffret de sécurité
13.4	Anschlußkonsole AGK 86.20	600 533	E	0,665	Terminal socket	Socle
13.6 13.7	Klemmensockel LFL LGK	600 516 600 523	E	0,160 0,166	Terminal socket	Socle
13.8	Steckerteil ST 18/7	716 089	E	0,035	Plug part	Douille pour prise
13.9	Befestigungsbügel für Anschlußkonsole	241 300 1202/7	E	0,151	Attachment bracket for terminal socket	Etrier pour socle
13.10 13.11	Flammenfühler QRA 2 QRA 53-C27	235 300 1201/2 600 580	E E	0,074 0,678	Flame sensor	Cellule
13.12	Zwischenstecker Nr. 9 Nr. 10	232 300 1205/2 232 300 1206/2	E E	0,008 0,007	Intermediate plug	Prise intermédiaire
13.13	Relais AGK 31, 230V, 50-60 Hz	704 125	E	0,100	Relay	Relais
13.14	Zeitzähler Typ 633.3/888 WGL30, WG30 230V, 50 Hz mit Kabel Nr. 8	240 100 8505/2	Z	0,050	Service hours counter	Compteur d'heures
14.	Zündtrafo				Ignition transformer	Transformateur d'allumage
14.1	Zündgerät ZG01, 230 V	603 126	E	0,382	Ignition transformer	Transformateur d'allumage
14.2	Zündkabel 550 mm lang 650 mm lang 750 mm lang 850 mm lang	235 300 1102/2 230 300 1110/2 230 300 1111/2 230 300 1112/2	E E E E	0,022 0,035 0,045 0,055	Ignition line	Ligne d'allumage
14.3	Befestigungsbügel	241 300 1103/7	E	0,180	Attachment bracket	Etrier
14.4	Stehbolzen 5 x 70	241 300 1105/7	E	0,028	Stay bolt	Entretoise



Bild Pict. Photo	Bezeichnung Brenner-Typenreihe Burner serie Type brûleur	Bestell-Nr. Order-No. No de commande	ca. kg appr. kg env. kg	Designation	Désignation
15.	Armaturen			Gas train	Rampe gaz
	Typ Rp Spannung/Frequenz			Type ID	Type DN
15.1	DMV-D 503/11 3/8" 110-120V/50-60 Hz	605 201	1,700		
	DMV-D 507/11 1/2"+3/4" 110-120V/50-60 Hz	605 203	2,200		
15.2	DMV-D 512/11 1"+1 1/2" 110-120V/50-60 Hz	605 205	4,700		
	DMV-D 520/11 2" 110-120V/50-60 Hz	605 207	5,500		
15.3	DMV-D 503/11 3/8" 220-240V/50-60 Hz	605 202	1,460		
	DMV-D 507/11 1/2"+3/4" 220-240V/50-60 Hz	605 204	2,200		
15.4	DMV-D 512/11 1"+1 1/2" 220-240V/50-60 Hz	605 206	4,700		
	DMV-D 520/11 2" 220-240V/50-60 Hz	605 208	5,800		
	Magnet komplett, für Typ Nr. Spannung/Frequenz			Solenoid, complete for Type No ID	Bobine, complet pour Type No DN
15.5	DMV-D 503/11 1011 110-120V/50-60 Hz	605 949	0,660		
	DMV-D 507/11 1111 110-120V/50-60 Hz	605 950	0,795		
	DMV-D 512/11 1211 110-120V/50-60 Hz	605 951	1,800		
15.6	DMV-D 503/11 1011 220-240V/50-60 Hz	605 940	0,656		
	DMV-D 507/11 1111 220-240V/50-60 Hz	605 941	0,795		
	DMV-D 512/11 1211 220-240V/50-60 Hz	605 942	1,800		
15.7	Flansch Rp 3/8 für DMV 503 605 225		0,160	Flange	Bride
	Rp 1/2 für DMV 503 605 235		0,158		
	Rp 1/2" für DMV 507 605 226		0,181		
	Rp 3/4" für DMV 507 605 227		0,173		
	Rp 1" für DMV 507 605 233		0,163		
	Rp 1" für DMV 512 605 228		0,266		
	Rp 1 1/2" für DMV 520 605 230		0,401		
	Rp 2" für DMV 520 605 231		0,321		
15.8	Druckregelgerät FRS 503 RP 3/8" 640 681		0,600	Pressure regulator	Régulateur de pression
	FRS 505 RP 1/2" 640 675		0,600		
	FRS 507 RP 3/4" 640 676		0,800		
	FRS 510 RP 1" 640 677		1,000		
	FRS 515 RP 1 1/2" 640 678		2,209		
15.9	Druckwächter GW 50 A5/1 5-50 mbar 691 378		0,186	Pressure monitor	Pressostat
15.10	Adapter-Set für GW 50 A5 (o. Bild) 605 251		0,085	Adaptor set (without picture)	Set d'adaption (sans photo)
15.11	Kugelhahn mit Innengewinde PN 40, Dichtung Teflon			Ball cock with internal thread	Robinet à bille
	RP 3/8 454 003		0,300		
	RP 1/2 454 004		0,321		
	RP 3/4 454 005		0,333		
	RP 1 454 006		0,622		
	RP 1 1/4 454 007		0,700		
	RP 1 1/2 454 008		0,750		
	RP 2 454 009		0,800		
15.12	Gasfilter WF 505, Rp 1/2 151 223 4012/0		0,320	Gas filter	Filtre gaz
	WF 507, Rp 3/4 151 223 4013/0		0,440		
	WF 510, Rp 1 151 223 4014/0		0,747		
	WF 515, Rp1 1/2 151 223 4015/0		0,800		
15.13	Hydraulikbremse Set für DMV 503/11 DMV 507/11 605 236 605 237		0,250 0,274	Hydraulic brake	Cartouche hydraulique
15.14	Steckerkabel Nr. 5 DMV 3-polig Nr. 12 GW 232 200 1210/2 232 200 1213/2		0,116 0,116	Connection cable	Câble de raccordement
15.15	O-Ring 8 x 3 Zündgasflansch 445 516		0,001	O-ring	Joint O
	10,5 x 2,25 Zündgasflansch 445 512		0,001		
	45 x 3 Anschlußflansch 445 518		0,001		
	57 x 3 Anschlußflansch 445 519		0,003		
	75 x 3,5 Anschlußflansch 445 520		0,003		
15.16	Verschlußschraube flach G1/8 mit O-Ring 409 040		0,005	Closing screw	Vis de fermeture
15.17	Leiterplatte (o. Bild) DMV 503 605 995		0,025	Conductor plate	Platine
	DMV 507 605 996		0,025		
	DMV 512/520 605 997		0,030		

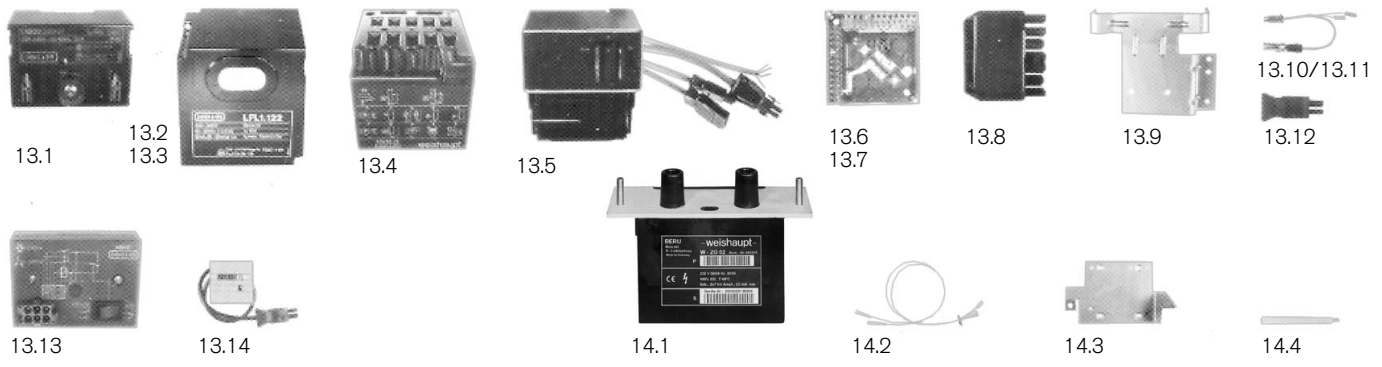
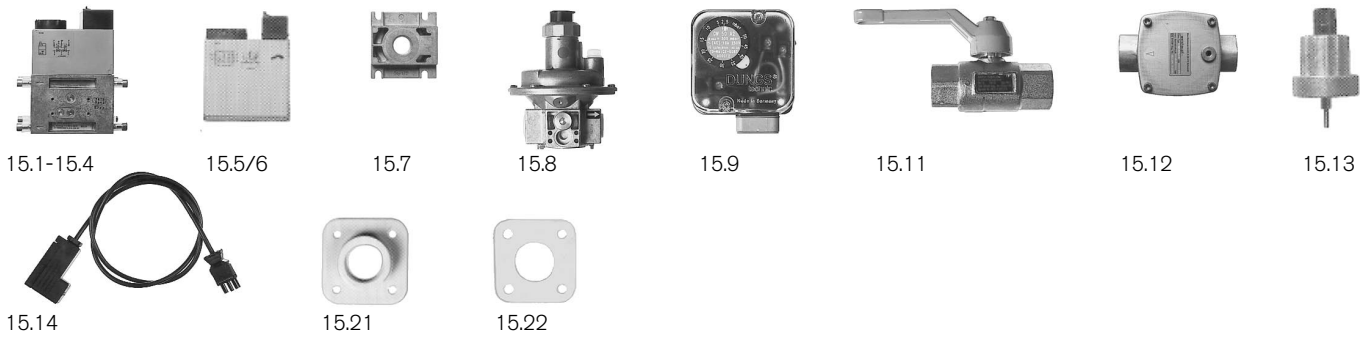

16.7

Bild Pict. Photo	Bezeichnung Brenner-Typenreihe Burner serie Type brûleur	Bestell-Nr. Order-No. No de commande		ca. kg appr. kg env. kg	Designation	Désignation
15.20	Anschlußflansch				Connection flange	Bride de raccords
15.21	Flansch G1	232 300 2601/7	E	0,134	Flange	Bride
15.22	Dichtung 76 x 76 x 2	232 300 2602/7	E	0,016	Sealing	Joint
16.	Verbindungsteile				Connection parts	Pièces pour liaison
16.1	Doppelnippel				Double nipple	Raccord fileté double
	R 3/8 x 50	139 000 2602/7	Z	0,035		
	R 1/4 x 50	139 000 2601/7	Z	0,028		
	R 1/2 x 50	139 000 2605/7	Z	0,050		
	R 3/4 x 50	139 000 2611/7	Z	0,062		
	R 1 x 50	139 000 2617/7	Z	0,097		
	R 1 1/2 x 50	139 000 2622/7	Z	0,126		
16.2						
	R 1/2 x 80	139 000 2607/7	Z	0,090		
	R 3/4 x 80	139 000 2612/7	Z	0,104		
	R 1 x 80	139 000 2639/7	Z	0,173		
	R 1 1/4 x 80	139 000 2635/7	Z	0,225		
	R 2 x 80	139 000 2626/7	Z	0,276		
	R 1 1/4 x 120	139 000 2636/7	Z	0,341		
	R 1 1/2 x 120	139 000 2623/7	Z	0,480		
	R 2 x 160	139 000 2627/7	Z	0,647		
16.3						
	R 1/2 x 180	139 000 2608/7	Z	0,235		
	R 3/4 x 180	139 000 2614/7	Z	0,278		
	R 1 x 180	139 000 2640/7	Z	0,436		
	R 1 1/2 x 180	139 000 2637/7	Z	0,539		
	R 1 1/2 x 200	139 000 2625/7	Z	0,500		
	R 2 x 200	139 000 2628/7	Z	0,942		
16.4						
	R 1/2 x 250	139 000 2629/7	Z	0,284		
	R 3/4 x 250	139 000 2647/7	Z	0,392		
	R 1 x 250	139 000 2648/7	Z	0,596		
	R 1 1/4 x 250	139 000 2649/7	Z	0,798		
	R 1 1/2 x 250	139 000 2651/7	Z	0,857		
16.5						
	R 1/2 x 300	139 000 2630/7	Z	0,373		
	R 3/4 x 300	139 000 2631/7	Z	0,474		
	R 1 x 300	139 000 2632/7	Z	0,712		
16.6	Winkel GF 92				Angle	Coude équerre
	1/2 x 1/2	453 100	Z	0,090		
	3/4 x 3/4	453 135	Z	0,158		
	3/4 x 1	453 136	Z	0,210		
	1 x 1	453 106	Z	0,236		
	1 1/4 x 1	453 154	Z	0,289		
	1 1/4 (GF 90)	453 107	Z	0,357		
	1 1/4 x 1 1/4	453 153	Z	0,396		
	1 1/2 x 1	453 151	Z	0,341		
16.7	Winkelverschraubung GF 97 (ohne Bild)				Angle screwing	Raccord
	3/4	453 422	Z	0,350		
	1	453 423	Z	0,520		
	1 1/4	453 426	Z	0,838		
	1 1/2	453 424	Z	0,600		
	2	453 425	Z	1,611		
16.8	Dichtung Gummikork				Sealing (without picture)	Joint (sans photo)
	27 x 38 x 2 R 3/4	441 010	Z	0,002		
	32 x 44 x 2 R 1	441 011	Z	0,002		
	42 x 56 x 2 R 1 1/4	441 032	Z	0,004		
	46 x 62 x 2 R 1 1/2	441 012	Z	0,004		
	60 x 78 x 2 R 2	441 024	Z	0,006		